



Hand-Deburring Tools - Classic Line

(Page 2 to 6)

- For Hand-Deburring of
- Edges - Straight, Inner & curved,
 - Both sides of - slot, key-ways, ribs, ridge, sheets,
 - Scraper for corner & surface finishing work
 - Hole front & back side



**Multi-Component Handle
based Deburring Tools**

(Page 7 & 8)

For best results, we offer Deburring Tools
with unique Blade & Handle design concepts



Multi-Cutting Edge Deburring Tools

(Page 9 to 12)

Break-through Design in the History of Deburring
Optimum use of entire cutting edge length



**Deburring Tool Head for
Inside (ID) & Outside (OD) Diameter**

(Page 13 to 15)

Quick reversal of tool for deburring of ID & OD



Burrs are the unwanted portion of metal which remain at the edges of components after machining. Deburring is therefore essential which is commonly done by filing or by using deburring machine tool. Filing off burr is time consuming and it also does not give smooth edge; whereas burr removal using deburring machine tool is not always possible or economical. **Deburring hand tools offer Fast, Efficient and Economical solution for burr removal.**

Application Overview: We offer Deburring tools for hand Deburring of Edges- Straight, Internal & Curved, Both sides of - slots, key-ways, Ribs, Ridge, Sheets, Corners, Single or both sides of Hole etc.

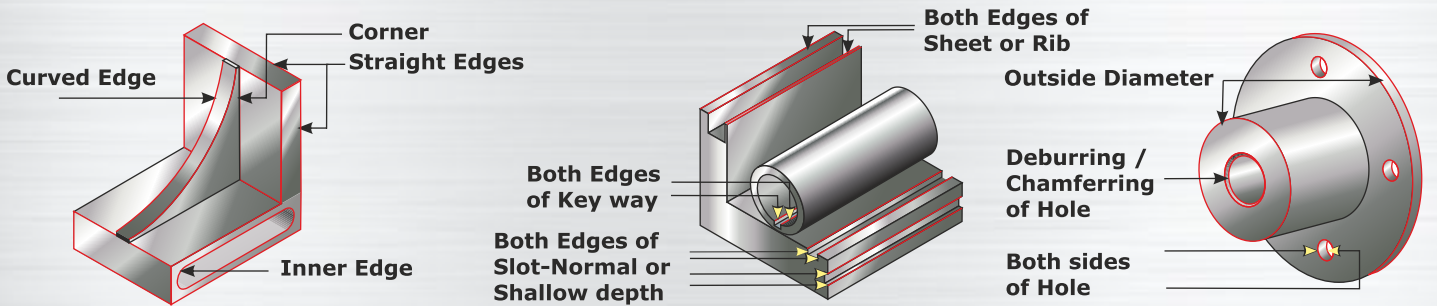

Variety of tools

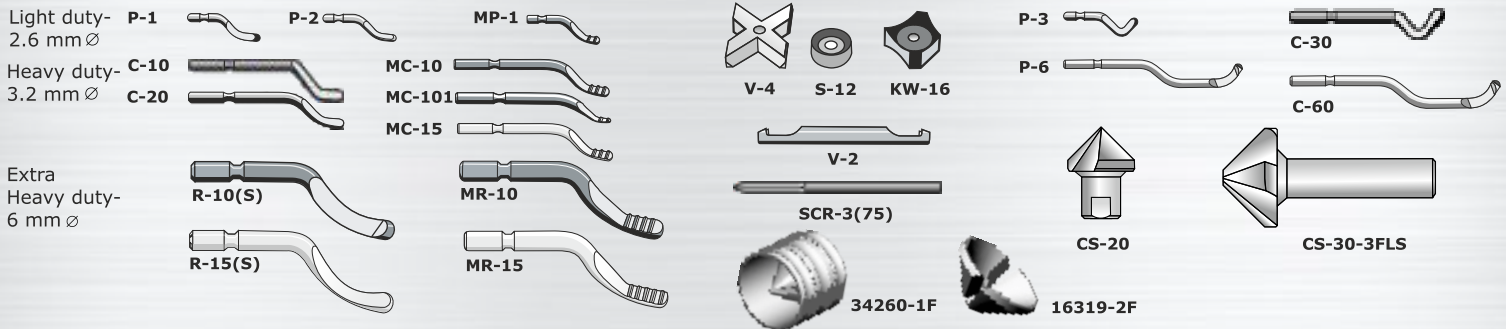

For Deburring of component materials such as Steel, Al., Copper, Brass, Cast Iron, Stainless Steel, Alloy Steel, hard plastic etc., blades of different shapes & cutting angles are available.

BLADES TYPE	SUITABLE FOR DEBURRING OF	BLADES TYPE	SUITABLE FOR DEBURRING OF
P1, C-10, R-10(S), MP-1, MC-10, MC-70, MR-10	Steel, Al., Copper etc.	C-100, C-150, Coated & M35 Blades	Hard Metals
P2, C-20, MP-2, MC-20, MC-40, MC-80	Cast Iron, Brass	S-12, V-2, V-4	Sheet / Ribs - Both sides
P3, P-6, C-30, C-60, MC-40	Sheet metal holes	KW-9, KW-16	Key-way / Slots
C-15, R-15(S), MC-15, MR-15	Stainless Steel	SCR-3, SCR-345, SCR-6(2), SCR-8	Surface finishing / Scraping, Corner cleaning
C-101, MC-101	Small holes	CS-12, CS-20, CS-30, CS-12-3FLS, CS-20-3FLS, CS-30-3FLS, CS-40-3FLS,	Hole deburring/ Chamfering
16316-2F, 22426-2F, 40586-2F, 34265, 34295	Inner & Outer Edge of Tube	16319-2F, 22429-2F, 40589-2F, 34260-1F, 34290-1F	Inner & Outer Edge of Tube

The Deburring Blades & Countersink Tools are made of High Speed Steel - M2 or M35 Grade material.

Hand - Deburring Tools Classic Line

Deburring Tools with Handle

DT-1 This is a Simple, Economical Tool. It has universal blade C-10 attached to a hexagonal handle with pocket clip. The blade cannot be replaced.

Packing Model	Includes
DT-1 (2) (31014)	2 pcs of DT-1
DT-1 (10) Set (86109)	10 pcs of DT-1



DT-2 In this the blade can be replaced. This includes Hexagonal handle with universal blade C-10.

Packing Model	Includes
DT-2 (31024)	1 pc of DT-2
DT-2 (5) Set (86059)	5 pcs of DT-2



DT-3 Here the blades can be replaced & stored from back side of the handle. The handle body is of ABS plastic & the blade holder is of polyacetal.

Packing Model	Includes
DT-3 (33033)	'D' Handle & 3 Blades C-10, C-20 & C-30



DT-3 (M)-SD

This is Polyacetal body handle & Metallic Blade Holder for longer life.
 Ergonomically designed.
 Has thumb rest. Grips well in Hand.
 Blades can be stored from backside.

Packing Model	Includes
DT-3(M)-SD (34034)	'D-SD' Handle & 3 Blades C-10, C-20 & C-30



DT-5-SD

Here the Blades can be replaced & the holder can be telescoped to reach & deburr the burrs at depth.
 Collet action ensures firm locking of plain surface holders.

Packing Model	Includes
DT-5-SD (34054)	'T-SD' Handle, DT(C)Holder & 5 Blades C-10, C-20, C-30, C-10(C) & C-15
DT-52-SD (34524)	'T-SD' Handle, DT(P) Holder & 2 Blades P1 & P2.



RDT-SD Rigid Deburring Tools (34064)

Extra Heavy duty deburring tool.
Strong, Sturdy & Rugged.

Type RDT-SD includes Handle 'R-SD' & Universal Blade R-10(S).

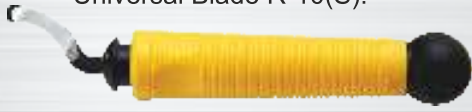

Key-Way/ Slot Deburrer KWS-SD (34074)

For simultaneous deburring of both edges of slot or key-vey. Four cutting edges -2 for std. depth of slot / key-vey & 2 for shallow depth. Includes Handle 'T-SD', telescopic holder KW, Blades KW-9 & KW-16.



Sheet / Rib Deburrer Set SDT (34084)

Excellent for deburring one or both edges of sheets / ribs. Width range 0 -12 mm. Cutting edge along the full circle on 2 sides.



'V' Shaped Sheet / Rib Deburrer VDT-SD (34094)

Unique Tool-has 4 nos 'V' shaped edges 2 nos for 1 to 12 mm width range & 2 nos for 0 to 4 mm width range. Includes handle 'T-SD', Telescopic holder VT & V-4 blade.



Sheet / Rib Deburrer V2-SD (34104)



V-2 Blade

- ✓ Double ended tool.
- ✓ Held & replaceable in collet type T-SD Handle.
- ✓ Deburrs both edges of sheet/ rib of upto 4 mm thickness from one side.
- ✓ Single edge deburring from another side of the tool.



DT-SD (3-in-1) Set (86319)

- ✓ This is a unique Deburring Tool with Handle which can hold three sizes of swivel blades viz. 'R' (6 mm \varnothing), 'C' (3.2 mm \varnothing) & 'P' (2.6 mm \varnothing)
- ✓ The handle has auto release system for easy change of blades & Holders.
- ✓ All the holders and blades can be stored from back side of the handle.
- ✓ Includes Handle 'R-SD', Holders SD-C & SD-P and 7 Blades R-15 (S), C-10, C-20, C-30, P-1, P-2 & P-3.



Handle shown with R-15(S) Blade.



Holder SD-C



Holder SD-P



Handle shown with SD-C Hoder & C-10 Blade.

Scraper for Surface finishing/ Scraping

Scraper SCR-3- (72034)

Triangular 3 mm A/F Scraper. Fixed Blade type.



Scraper SCR-3 (75) - SD (74754)

Triangular 3 mm A/F (75mm) Scraper. Replaceable Blade type.



Scraper SCR-8 (75084)

Triangular 8mm A/F Scraper. Replaceable type.



Scraper SCR-8-SD (74084)

Triangular 8mm A/F Scraper with Swiss Design handle. Replaceable type.

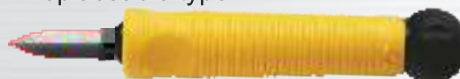

Scraper SCR-6 (2) - SD (74064)



SCR- 6 (2) Combo Scraper

- ✓ Double ended tool.
- ✓ Held & replaceable in collet type T-SD Handle.
- ✓ 6 mm A/F Triangular Scraper on one side.
- ✓ Internal Scraper on the another side.



Ceramic Deburring Tools

Features & Applications

- ✓ Deflashing & scraping of plastic components.
- ✓ Very long life of Ceramic Blade - Cutting edge all along.
- ✓ Blade can be ground to suit the application.
- ✓ Blade is replaceable in the handle.

Ceramic Blade C-1 (77101)



CT Ceramic Tool (77104)



Includes Handles T-SD & Ceramic Blade C-1

Ceramic Scraper SCR-3 (77201)

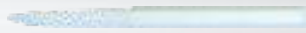

3 mm Triangular Scraper

CS Ceramic Tool (77204)



Includes SCR-3 Ceramic Scraper & SD-1 Handle

Countersink Tools



2 Flute Countersinks

For hole deburring & Chamfering.
3 sizes upto 30 mm for use by hand.
12 mm shank size for all tools.

Type	For size upto
CS-12 (48120)	12 mm
CS-20 (48200)	20 mm
CS-30 (48300)	30 mm

Handles Common handle for all 3 tools. Type CSH, CS-Revolving.



CSH Handle (46014)



CS- Revolving Handle (48024)

Countersink Set - Revolving (48034)



Includes CS-12, CS-20 and CS-30 Countersinks with
CS-Revolving Handle
Offered only in certain Countries.



3 Flute, Long Shank Countersinks

Upto size 40mm for use with m/cs.
For hole/ slot/ corner
deburring/ chamfering.

Type	For size upto
CS-12-3FLS (48130)	12 mm
CS-20-3FLS (48230)	20 mm
CS-30-3FLS (48330)	30 mm
CS-40-3FLS (48430)	40 mm

Deburring Tools Sets & Kits

Deburring Tools set for Plastic Deflashing

DT-PP SET (86209)
For deflashing & scraping of a Plastic components.
Includes DT-2 handle with C-15 blade & SCR-3



DT-2 handle with C-15 Blade



SCR-3

Deburring Tool for Stainless Steel

DT-SS SET (86309)
Includes T-SD handle, R-15 (S) blades, C-15 blade & SD-C holder



SD-C Holder with C-15 Blade



DTK-5 Comprehensive Kit (86809)

Includes -
T-SD (2 No) & DT Handles, DT (P), VT & KW Holders, Scraper SCR-8, Countersink tool CS-20 and CS Holder, Deburring Blades P-1, P-2 (2 each), C-10 (5 pcs), C-20, C-30, C-10 (Coated), C-15 & C-101 (1 each), Key-way/ Slot Deburring Blades KW-9 & KW-16, Shet/ Rib Deburring Blade V-4



Promo- 1 Set (84029)
Contains :
D-SD Handle & 10 Nos. Deburring Blades- 2 Nos. each of C-10, C-20, C-101 1 No. each of C-30, C-15, C-35, and C-10(C)



Universal Kit (86909)















Includes :
5 Handles – D-SD, T-SD, R-SD, SD-1 & Ratchet Handle CSH-R(S)
21 Nos. 3.2 mm swivel blades – 5 pcs. each of C-10 & C-20 2 pcs. each of C-30, C-101, C-100, C-20, C-15 & 1 pc. of C-60 blade
5 Nos. 6 mm blades – 2 pcs. of R-10(S) & 3 pcs. of R-15(S)
2 Nos. Scraper – SCR-3(75 mm) & SCR-6(2) Combo, Sheet/ Rib Deburring tool V-2 & V-4 with telescopic holder VT
Key-Way / Rib deburrer KW-16 with telescopic holder KW
DT® telescopic holder for all 'C' blades.
CS-20 Countersink tool & C-1 Ceramic Blade.

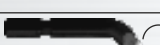

Promo- 2 Set (84039)
Contains :
D Handle & 10 Nos. Deburring Blades- 5 Nos. each of C-10 & C-20

Deburring Blades

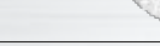
Unless specified the Blades are made of HSS-M2 Grade material.

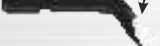
BLADES TYPE	APPLICATIONS	PACK QUANTITY	BLADES TYPE	APPLICATIONS	PACK QUANTITY
P-1 (11010)	 Universal Blade. For light duty & small components deburring of Steel, Al., Copper, Zinc, Plastics, etc.	10	C-15 (12151)	 For stainless steel & hard plastic.	10
P-2 (11020)	 For small components of C.I. & Brass	10	C-101 (12110)	 For small holes from 1.5 mm in Steel & Aluminium.	10
P-3 (11030)	 For both sides of sheet metal holes upto 6 mm thickness.	10	Coated Blades	Titanium Nitride (TIN) coating on C-10, C-20 & C-30 Blades for hard metal & longer life application.	10
P-6 (11060)	 For backside deburring upto 20 mm thickness.	5	C-60 (12600)	 For backside deburring upto 20 mm thickness.	5
Coated Blades	Titanium Nitride (TIN) coating on P-1, P-2 Blades for hard metal & longer life application.	10	C-OR (12610)	 For internal O-Ring grooves upto 3 mm	1
C-10 (12100)	 Universal Blade. For materials having spiral chips such as Steel, Al., Copper, Zinc, Plastics, etc.	10	C-10 Carbide (12103)	 Carbide Blade for Hardened Components	2
C-20 (12200)	 For materials having brittle burr such as C.I. & Brass.	10	R-10(S) (13100)	 Universal Blade for Extra Heavy duty deburring application. For materials having spiral Chips such as Steel, Al., Copper, Zinc, etc.	5
C-30 (12300)	 For simultaneous deburring of inner & outer edges of sheet metal holes up to 10 mm thickness.	10	R-10(S) L+R (13200)	 Universal Blade for Extra Heavy Duty Deburring. Both direction Application.	5
C-35 (12350)	 For straight edges on most materials.	10	R-15(S) (13151)	 For Stainless steel application	5
HSS M35 grade Blades C-100 = C-10 Blade in HSS M35 Grade C-150 = C-15 Blade in HSS M35 Grade					

Key-way / Slot Deburring Blades

(Four cutting edges. 2 for std. depth of slot/key-way & 2 for shallow depth.)

KW-9 (27090)



For width 0-9 mm

KW-16 (27160)



For width 0-16 mm

Sheet / Rib Deburring Blades

S-12
(26120)



Cutting edge along full circle and on 2 sides for long life.

V-2
(23020)



Double ended for both edges deburring up to 4 mm from one side and single edge from another side.

V-4
(26040)



4 nos 'V' shaped edges - 2 nos for 1 to 12 mm width & 2 nos for 0 to 4 mm width range

Scraper Blades

SCR-3(75)
(72750)

 Triangular 3 mm A/F Scraper - 75 mm length

SCR-345
(72450)

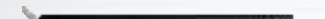
 Triangular 3 mm Internal Scaper 75 mm length

SCR-6(2) Combo
(74060)

 Double ended 6 mm Triangular Scraper on one side & Internal Scaper on another side.

SCR-8 (75080)

 Triangular 8 mm A/F Scraper

Handles

D
(53013)



ABS Plastic handle. Holds all 'C' Blades.

D-SD
(54014)

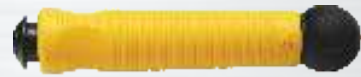

Polyacetal Handle. Holds all 'C' Blades.

T-SD
(54024)



Holds all telescopic holders.

R-SD
(54034)



Holds all 'R' Blades & SD-C & SD-P Holders

SD-1
(54044)



Holds SCR-3 Scraper blades

HOLDERS

DT(C)
(62010)

 Holds all 'C' Blades.

DT(P)
(62020)

 Holds all 'P' Blades.

KW
(62030)

 Holds key-way / slot Deburring Blades.

VT
(62040)

 Holds V-4' Blade.

SD-C
(64015)

 Holder for 'C' Blade.

SD-P
(64025)

 Holder for 'P' Blade.

CS- Short
(62050)



CS- R
(62090) - Revolving



CS- Long
(62060)

 Holds all 2 - Flute Countersinks

For best results, we offer Deburring Tools with unique Blade & Handle design concepts



MICRO Tools - Fix Blade

MT-1 (38014) with C-101



MT Scraper (38024) with SCR-3

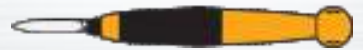

ECONO Tools - Interchangeable Blade

ET-1 (38030) with P-1

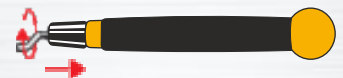

ET-2 (38040) with C-10

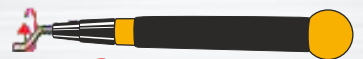

COMFORT GRIP 1 Tools

CG-1 (38114) with P-1



CG Scraper (38134) with SCR-3 (75)



COMFORT GRIP 2 Tools

RDT- MK (38244)

R-SD-MK Handle with Rugged blades R-10(S), R-15(S)
Ø 6 mm Deburring blades.



DT- MK (38334)

D-SD-MK Handle with C-10, C-20, C-30
Ø 3.2 mm Deburring blades.

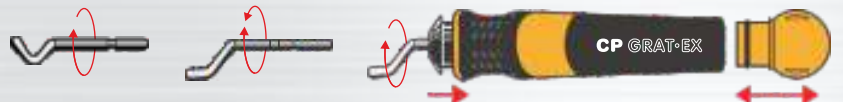

DT- 5C- MK (38324)

T-SD-MK Handle with C-10, C-20,
C-30, C-15 & C-35 - Ø 3.2 mm
Deburring blades & DT(C) telescopic holder



DT- 3P-MK (38214)

T-SD-MK Handle with P-1, P-2, P-3
Ø 2.6 mm Deburring blades & DT(P) telescopic holder



V-2-MK (38254)

T-SD-MK Handle with Double ended V-2 blade
for both edge upto 4 mm width and single edge
Ø 6.5 mm Deburring blade.



VDT-MK (38264)

T-SD-MK Handle with V-4 Sheet/ Rib Deburring
blade (2x1-12 / 2x-4mm) and VT telescopic holder



KWS-MK (38274)

T-SD-MK Handle with KW-9 (1-9mm), KW-16 (1-16mm) blades and KW telescopic holder

**SCR-6(2)-MK** (38284)

T-SD-MK Handle with SCR-6(2) Combo Scraper
Double ended - Triangular & Internal Ø 6.5 mm blade.

**CT-MK Ceramic** (38294)

T-SD-MK Handle with C-1 Ceramic blade. The safe general purpose tool for equal results in plastics, metal and hardened materials.

**Handles****ET-1 Handle** (58014)

Holds all P blades

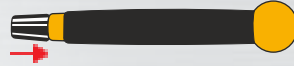
**ET-2 Handle** (58024)

Holds all C blades

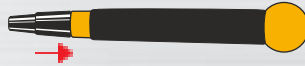
**CG-1 Handle** (58034)

Holds all P blades

**CG Handle** (58054)

Holds 3.2 mm Ø Scraper

**T- SD- MK Handle** (58064)

Holds all Telescopic holders

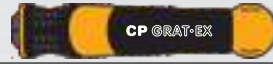
**D- SD- MK Handle** (58074)

Holds all C blades

**R- SD- MK Handle** (58084)

Holds all R blades

**Telescopic Holders****DT (C)** (62010)

Holds all 'C' Blades

**DT (P)** (62020)

Holds all 'P' Blades

**VT** (62040)

Holds 'V-4' Blade

**KW** (62030)

Holds key-way / slot Deburring Blades

**Special MK Handle based Sets / Kits****Promo- 1 Set** (88039)

Contains :
D-SD-MK Handle &
10 Nos. Deburring Blades-
2 Nos. each of
C-10, C-20, C-101
1 No. each of
C-30, C-15, C-35,
and C-10(C)

Packaging**Smart Kit** (88909)

SMART KIT Includes : 1 Pc. Each of MT-1, MT Scraper, ET-2, RDT-MK, DT-MK, V-2-MK, SCR-6(2)-MK, CT-MK, F-MK, 10 pcs. Pack of 3.2 mm Blades containing 2 pcs. each of C-10, C-20, C-101 & 1 pc. each of C-15, C-35, C-30 & C-10 (C) and 5 pcs. Pack of 6 mm Blades containing 2 pcs. of R-10(S) & 3 pcs. of R-15(S).



Collet action ensures firm locking of plain surface holders.

Break-through Design in the history of Deburring



Existing Deburring Blades



Effective Cutting Edge Portion

New Multi-Cutting Edge Deburring Blades

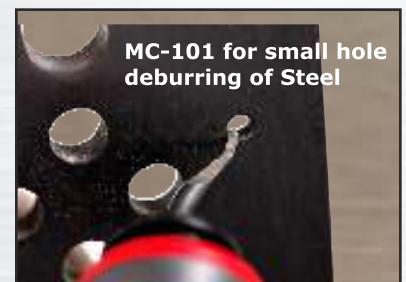
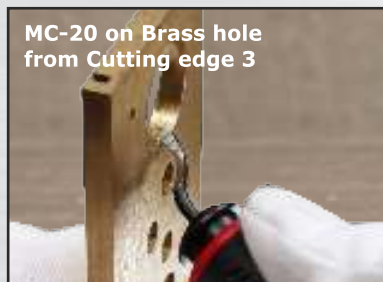
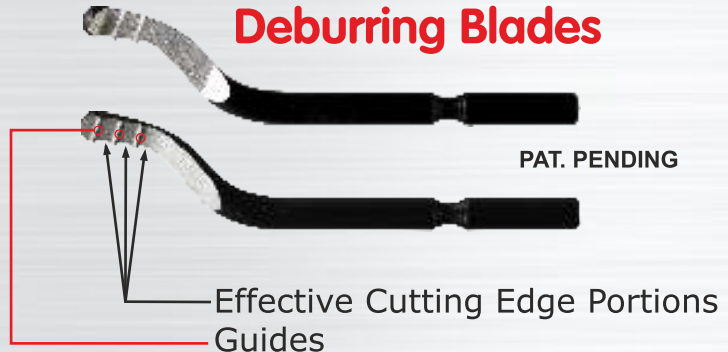

Try and Experience the difference

Superior Deburring Experience



Features

- Multi-Cutting Edge Design
- Multiple segments of cutting edges separated with guides
- 2 segments in Ø2.6 mm and upto 5 segments in Ø6 mm blade
- Optimum use of entire cutting edge length
- Fit in all Handles & Holders in the market
- Advanced Design – Precision Engineered
- Longer Life, Greater Value

ECONO Tools - Interchangeable Blade

MC-1 (38033) ET-1 Handle with MP-1 Deburring Blade

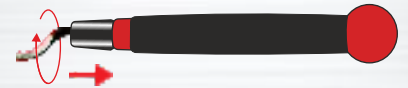

MC-2 (38043) ET-2 Handle with MC-10 Deburring Blade



COMFORT GRIP 1 Tools

MC-3 (38113) CG-1 Handle with MP-1 Deburring Blade



MC-4 (38123) CG-2 Handle with MC-10 Deburring Blade



COMFORT GRIP 2 Tools

RDT-MC (38243)

R-SD-MK Handle with Rugged blades
MR-10, MR-15
Ø 6 mm Deburring blades.



DT-MC (38333)

D-SD-MK Handle with
MC-10, MC-20, MC-101
Ø 3.2 mm Deburring blades.

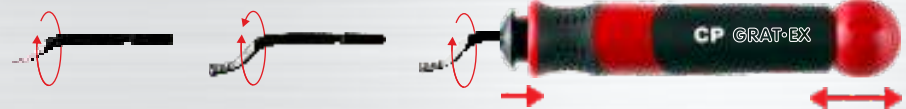

DT-5-MC (38323)

T-SD-MK Handle with
MC-10, MC-20, MC-101, MC-15
& MC-10(C) - Ø 3.2 mm Deburring blades
& DT(C) telescopic holder

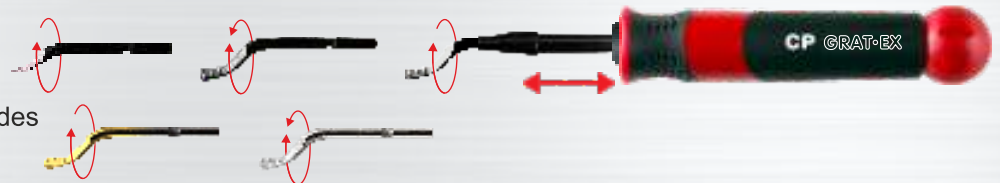

DT-2P-MC (38213)

T-SD-MK Handle with MP-1, MP-2
Ø 2.6 mm Deburring blades & DT(P) telescopic holder



DT-SD-MC (3-in-1) Set

(38513)
R-SD-MK Handle with
SD-C & SD-P Holders and
6 blades - MR-10, MC-10,
MC-20, MC-101,
MP-1 & MP-2

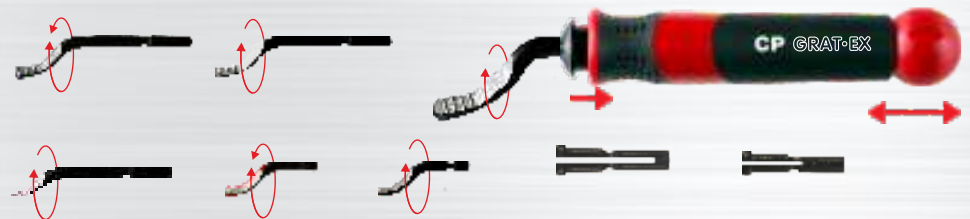

HS-80 Scraper (78080)

4.2 mm Triangular Hollow Scraper. Double ended.
Length 80 mm. Blade Material : CR115.



HS-120 Scraper (78120)

7.4 mm Triangular Hollow Scraper. Double ended.
Length 120 mm. Blade Material : CR115.

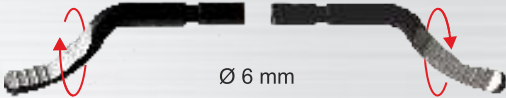
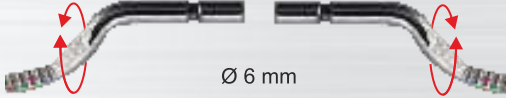
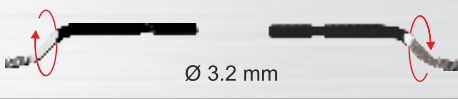
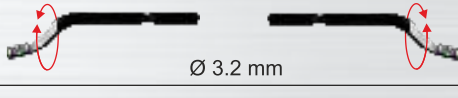
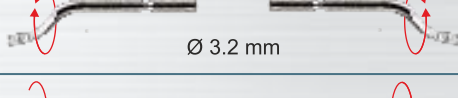
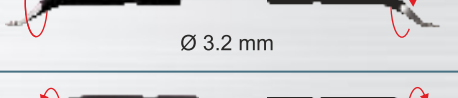
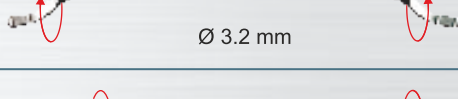
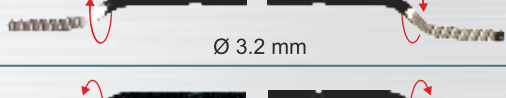
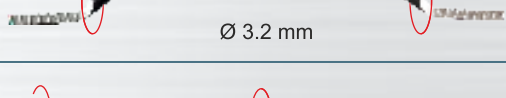
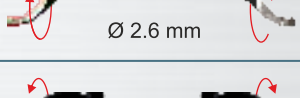
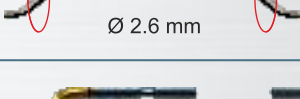
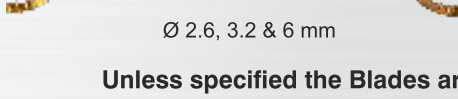

BLADES TYPE	BOTH SIDE VIEW	NO. OF CUTTING EDGE SEGMENTS	APPLICATION	PACK QUANTITY
MR-10 (23100)		4	Universal Blade for Extra Heavy duty deburring application. For materials having spiral Chips such as Steel, Al, Copper, Zinc etc.	5
MR-15 (23151)		5	For Stainless steel application	5
MC-10 (22100)		3	Universal Blade for materials having spiral Chips such as Steel, Al, Copper, Zinc, Plastics etc.	10
MC-20 (22200)		3	For materials having brittle burr such as C.I. & Brass	10
MC-15 (22151)		3	For Stainless steel & hard plastic.	10
MC-101 (22110)		2	For small holes from 1.5 mm in Steel & Aluminium.	10
MC-40 (22400)		2	Special Blade for Hole Deburring of all Metals.	10
MC-70 (22700)		8	Long lasting Blade with 8 cutting edges for straight edge deburring of Steel, Al,Cu, Zinc etc.	10
MC-80 (22800)		8	Long lasting Blade with 8 cutting edges for straight edge deburring of C.I., Brass etc.	10
MP-1 (21010)		2	Universal Blade. For light duty & small components deburring of Steel, Al, Copper, Zinc, Plastics etc.	10
MP-2 (21020)		2	For small components of C.I. & Brass	10
Coated Blades		2 to 5	Titanium Nitride (TiN) coating of all above blades for hard metal & longer life application	5/10

Unless specified the Blades are made of HSS-M2 Grade material.

Hollow Scraper Blade

Hollow Scraper 80
(76080)

Double ended triangular Hollow scraper of 4.2 mm.



Hollow Scraper 120
(76120)

Double ended triangular Hollow scraper of 7.4 mm.



Handles

ET-1 Handle

(58013) Holds all 'MP' blades

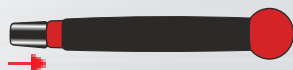

ET-2 Handle

(58023) Holds all 'MC' blades



CG-1 Handle

(58033) Holds all 'MP' blades



CG-2 Handle

(58043) Holds all 'MC' blades



Handle For HS-80 Scraper
(58053)



D- SD- MK Handle

(58073)

Holds all 'MC' blades



T- SD- MK Handle

(58063)

Holds all Telescopic holders



R- SD- MK Handle

(58083)

Holds all 'MR' blades



Handle For HS-120 Scraper
(58093)





Promo Set (88040)

Contains :

Promotion Set of Multi-Cutting Blades with Multi Component Handle & 10 blades of 3.2 mm Ø Set Includes :
D-SD-MK Handle with 10 Nos.
Deburring Blades -2 Nos. each of MC-10, MC-20, MC-15, MC-101 & MC-40.



Hollow Scraper 80

Promo Set (88050)

Contains :

Handle & 3 pcs. of HS-80 Double ended triangular Hollow scraper of 4.2 mm.



MULTI CUT KIT (88080)

Contains :

1 Pc. Each of Multi-Cutting Tools MC-2, RDT-MC, DT-MC, Hollow Scraper 80, 10 pcs. Pack of 3.2 mm Blades containing 2 pcs. each of MC-10, MC-20, MC-101 & 1 pc. each of MC-15, MC-40, MC-10(C) & MC-20 © and 5 pcs. Pack of 6 mm Blades containing 3 pcs. of MR-10 & 2 pcs. of MR-15.



MR-10 on St. Edge of Steel from Cutting Edge 3



MR-15 on St. Edge of SS from Cutting Edge 5



MC-101 on Small Hole of Steel from Cutting Edge 2



MC-20 on Brass Hole from Cutting Edge 2



MC-10 on St. Edge of Cu. from Cutting Edge 2



MC-101 on St. Cutting Edge of Acrylic from Cutting Edge 2

Patented

Deburring Tool Head

for

Inside (ID) & Outside (OD) Diameter

- Rigid, one piece construction - made from HSS (M2) grade material
- Quick reversal of tool for deburring of ID & OD
- Two Flute tools in 3 sizes with 60° & 90° included angle cover range from : 5/8" to 2⁷/₁₆" (16 to 62 mm) of ID / Holes and 5/8" to 2⁹/₃₂" (16 to 58 mm) of OD
- Single Flute tool with 60° & 90° included angle cover range from : 5/32" to 1¹³/₁₆" (4 to 46 mm) of ID / Holes and 5/32" to 1²¹/₃₂" (4 to 42 mm) of OD
- The tools can be used :
 - Manually with hand held holder / handle OR
 - Manually with power driven tool OR
 - With Machine tool

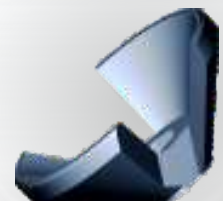
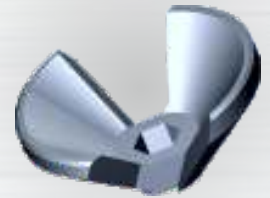
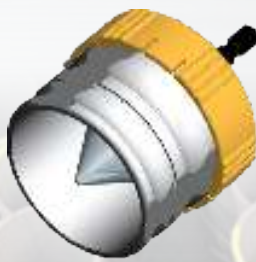

Deburring Tool Head for Inside (ID) & Outside (OD) Diameter

Product Name	Product Code	No. of Flutes	Included Angle	Deburring Range for Outside Diameter	Deburring Range for Inside Diameter / Holes	Picture
IDOD 16316	16316-2F	Two	60°	16 to 31 mm (5/8" to 1 1/4")	16 to 35 mm (5/8" to 1 3/8")	 + 
IDOD 16319	16319-2F	Two	90°	16 to 31 mm (5/8" to 1 1/4")	16 to 35 mm (5/8" to 1 3/8")	 + 
IDOD 22426	22426-2F	Two	60°	22 to 42 mm (7/8" to 1 21/32")	22 to 46 mm (7/8" to 1 13/16")	 + 
IDOD 22429	22429-2F	Two	90°	22 to 42 mm (7/8" to 1 21/32")	22 to 46 mm (7/8" to 1 13/16")	 + 
IDOD 40586	40586-2F	Two	60°	40 to 58 mm (1 9/16" to 2 9/32")	40 to 62 mm (1 9/16" to 2 7/16")	 + 
IDOD 40589	40589-2F	Two	90°	40 to 58 mm (1 9/16" to 2 9/32")	40 to 62 mm (1 9/16" to 2 7/16")	 + 
IDOD 34260	34260-1F	One	60°	4 to 42 mm (5/32" to 1 21/32")	4 to 42 mm (5/32" to 1 21/32")	 
IDOD 34290	34290-1F	One	90°	4 to 42 mm (5/32" to 1 21/32")	4 to 42 mm (5/32" to 1 21/32")	
IDOD 34265	34265	34260-1F Tool with Holder Assembly for use with driver				 
IDOD 34295	34295	34290-1F Tool with Holder Assembly for use with driver				 
Ratchet Handle 46030	46030	Ratchet Handle with Auto lock 1/4" Hex bit holder				
Non-Slip Holder	60010	Non-Slip Holder with 1/4" Hex bit for use with Machines				
1/4" Hex Bit Holder	60020	1/4" Hex Bit Holder for use with 2 Flute IDOD Tools.				
Auto-Lock for 1/4" Hex Bits	60040	Auto-Lock for 1/4" Hex Bits				

All above tools are also available with FUTURA (TiAlN) coating for long life & Steel application.



IDOD 60 Kit

(16586)

includes :

- 1 pc. Each of IDOD 16316, 22426, 40586,
- Ratchet Handle, Non-Slip Holder,
- Auto Lock for 1/4" Hex Bits &
- 3 pcs. of 1/4" Hex Bit Holders



IDOD 90 Kit

(16589)

includes :

- 1 pc. Each of IDOD 16319, 22429, 40589,
- Ratchet Handle, Non-Slip Holder,
- Auto Lock for 1/4" Hex Bits &
- 3 pcs. of 1/4" Hex Bit Holders



CP GRAT·EX Deburring Tools - Applications



Heavy Duty



Extra-Heavy Duty



Holes / Countersink



Ceramic Tool



Scraper



Internal Scraper



Key-way / Slot



Single or Double edge



Sheet / Rib



MR-10 on-St. Edge of Steel from Cutting Edge 3



MC-101 on Small Hole of Steel from Cutting Edge 2

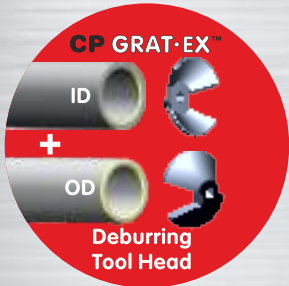

MC-20 on Brass Hole from Cutting Edge 2



MC-10 on St. Edge of Cu. from Cutting Edge 2



Distributed by :

Your U.S. Source for CP GRAT-EX

Sourcing or Surplus, Inc!!!
 859-331-8376 * 859-331-8476 fax
sales@sourcingorsurplus.com email
www.sourcingorsurplus.com
We ONLY sell through distribution.
We support our customers, we do not compete with them.